

PERMIT

CITY OF NAPOLEON - BUILDING DEPARTMENT
255 West Riverview Avenue, Napoleon, Ohio 43545 - 419-592-4010

Permit No. 856-77E Issued 11/14/77 date

Job Location 610 Haley Ave. address

Lot na sub-div or legal discript

Issued By Ronald D. Sonnenberg building official

Owner John Ritter 592-5237 tel.

Address 610 Haley Ave.

Agent Sherm Smith 592-7791 tel.

Address Rt. 2 Napoleon, Ohio

Description of Use New 100 amp service entrance.

Residential XX(2) no. dwelling units

Commercial _____ Industrial _____

New _____ Add'n. _____ Alter _____ Remodel XX

Mixed Occupancy _____

Change of Occupancy _____

Estimated Cost \$ 300.00 100.00 FURNACE

Estimated Cost \$ 300.00

ZONING INFORMATION

district	lot dimensions	area	front yd	side yds	rear yd
max hgt	no pkg spaces	no ldg spaces	max cover	petition or appeal req'd	date appr

WORK INFORMATION:

Size: Length _____ Width _____ Stories _____ Ground Floor Area _____

Height _____ Building Volume (for demo. permit) _____ cu. ft.

Electrical: New 100 amp service and panel. brief description

Plumbing: _____ brief description

Mechanical: _____ brief description

Sign: _____ type _____ Dimensions _____ Sign Area _____

Additional Information: Wiring shall conform to the N.E.C. 1975 edition.

Date 11-29-77 Applicant Signature Sherman Smith owner-agent

FEES	BASE	PLUS	TOTAL
<input type="checkbox"/> BUILDING			
<input checked="" type="checkbox"/> ELECTRICAL	\$3.00	---	\$3.00
<input type="checkbox"/> PLUMBING			
<input type="checkbox"/> MECHANICAL			
<input type="checkbox"/> DEMOLITION			
<input type="checkbox"/> ZONING			
<input type="checkbox"/> SIGN			
WATER TAP			
SEWER TAP			
TEMP. ELECT.			
ADDITIONAL PLAN REVIEW	Struct. _____ hrs		
	Elect. _____ hrs		
TOTAL FEES.....			\$3.00
LESS MIN. FEES PAID _____ date			-0-
BALANCE DUE.....			

Date: 10-25-77

Distribution Superintendent
Building Inspector - Building Department

Installation of 100 AMP. electrical
located AROUND CORNER FROM EXISTING.

Address: JOHN RITTER -
HALEY AVE.

Not Approved

10 25 - 77
Date

856-77E

\$3.00

CITY OF NAPOLEON
BUILDING INSPECTION DEPARTMENT
APPLICATION FOR ELECTRICAL PERMIT
(PLEASE PRINT OR TYPE)

The undersigned hereby makes application for the installation, replacement, or alteration of electrical equipment as herein specified, agreeing to do all such work in strict accordance with the City of Napoleon's adopted Electrical Code for 1, 2 and 3 Family Buildings.

Owner's Name JOHN RITTER Address 610 HALEY Tel. 592-5237

Contractor's Name SHERM SMITH Address Rt. 2 NAP. Tel. 592-7791

LOT INFORMATION:

Location of Project 610 HALEY Zoning District "B"

BUILDING INFORMATION:

Single Family _____ Double Family X Multiple Family _____

New Construction _____ Existing _____ Addition _____

Replacement _____ Remodel _____ Service Change X

Size: Total Square Foot Per Floor _____ No. of Stories _____

DESCRIPTION OF WORK

Size of Service 100 AMP. Service Change Only YES (Yes or No)

SOUTH APT. #NEW PANEL

Total Number of New Circuits _____
Excluding Appliance Circuits _____

APPLIANCE CIRCUITS: (indicate quantity)

Electric Range _____ Range Hood _____ Clothes Dryer _____ Dishwasher _____

Air Conditioner _____ Attic Fan Blower _____ Room Exhaust Fan _____

Disposal _____ Hot Water Heater _____ Electric Oven _____

Require Temporary Electric _____ (Yes or No)

Note: G.F.I.C. required for all temporary electric with approved ground rod at service

APPLICATION FOR PERMIT SHALL BE ACCOMPANIED BY TWO COMPLETE SETS OF PLANS INCLUDING: ELECTRICAL LAY-OUT AND RISER DIAGRAM.

ESTIMATED COST OF COMPLETED PROJECT: \$300.00

DATE 11-11-77

APPLICANT'S SIGNATURE Sherman Smith
OWNER-CONTRACTOR-AGENT

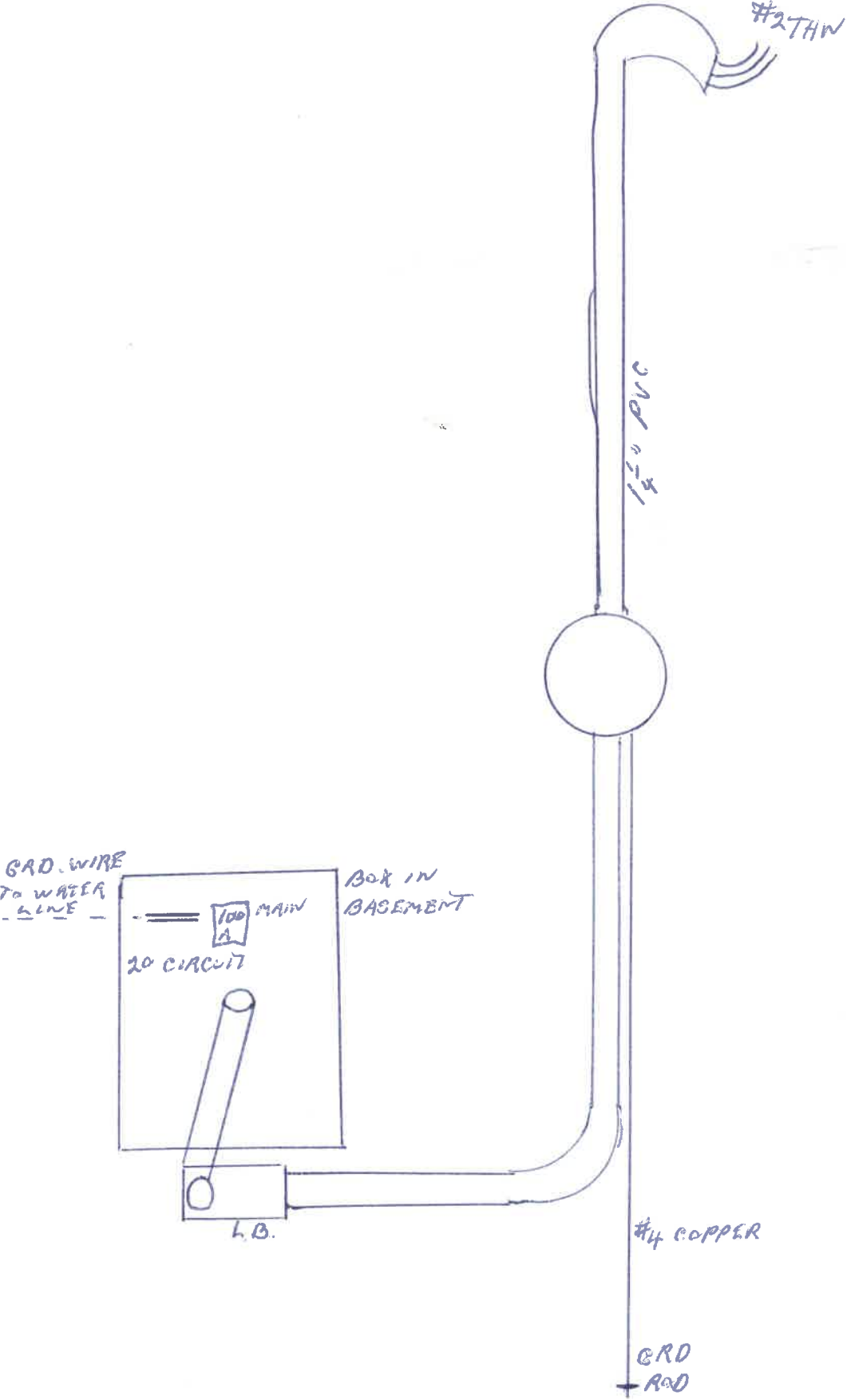

GRD. WIRE
TO WATER
LINE

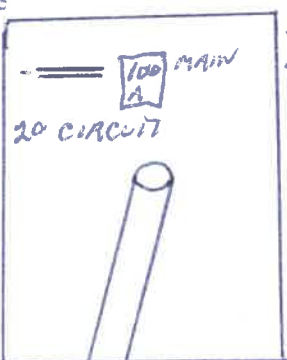

BOX IN
BASEMENT

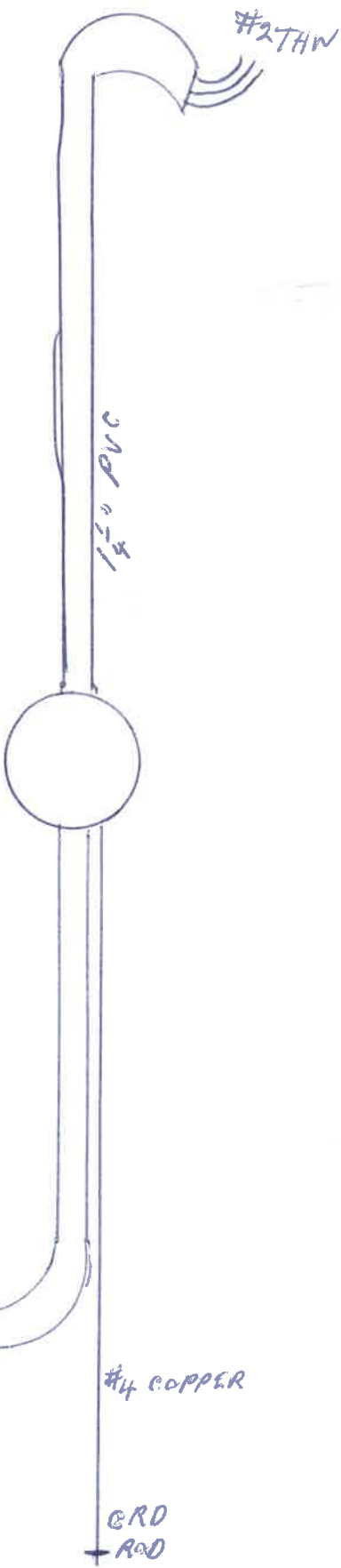

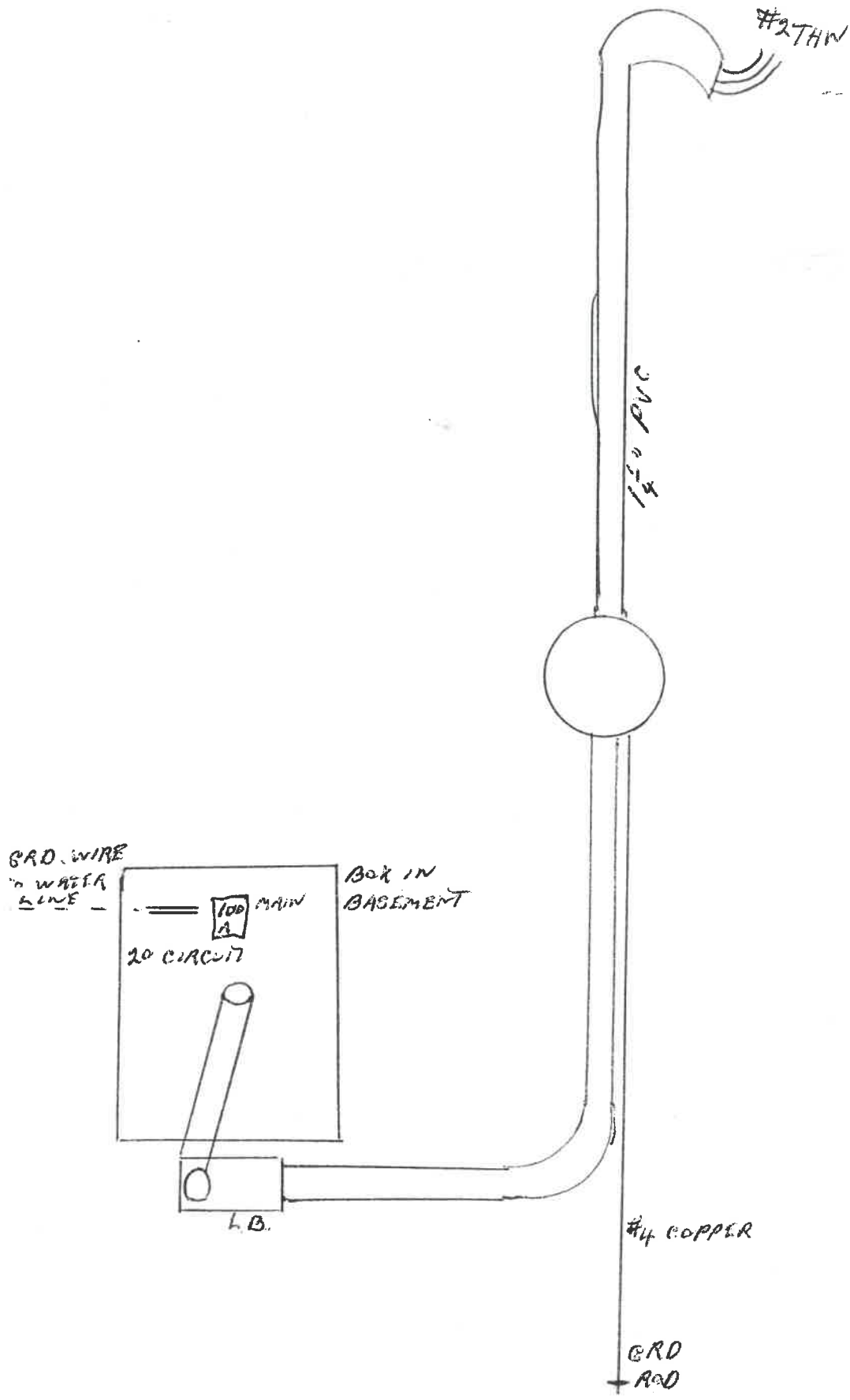

856-77

\$ 3.00

CITY OF NAPOLEON
BUILDING INSPECTION DEPARTMENT
APPLICATION FOR HEATING PERMIT
(PLEASE PRINT OR TYPE)

The undersigned hereby makes application for the installation, replacement or alteration of a heating system or device as herein specified, agreeing to do all such work in strict accordance with the City of Napoleon's adopted Mechanical Code for 1, 2 and 3 Family Buildings.

Owner's Name JOHN RITTER Address 610 HALEY 592-5237

Contractor's Name VONDEYLE PBLG+ATC ^{INC} Address 10806 LENWOOD Tel. 592-4756

BUILDING INFORMATION:

Single Family Double Family Multiple New Construction

Addition Remodel Replacement No. of Stories 2

DESCRIPTION OF WORK

Heating System - Warm Air Hot Water Steam Electric

Unit Heaters Unit Gas Heaters Other

Type - Gravity Forced Radiant

No. of Thermostatical Heating Zone ONE

Hot Water - One Pipe Two Pipe Series Loop

Electric Heat - No. of Circuits Other

Total Heat Loss of Area to be Heated 98752

Rated Capacity of Furnace/Boiler 137000 BTU

No. of Furnaces ONE No. of Hot Air Pans 6

No. of Hot Water Radiators Type of Fuel NAT. GAS

Heating Units Located: Crawl Space Floor Level Suspended

Roof or Exposed to Outside Air Attic Other BASEMENT

APPLICATION FOR PERMIT SHALL BE ACCOMPANIED BY TWO COMPLETE SETS OF PLANS INCLUDING: LOCATION OF FURNACE OR UNIT HEATERS AND SIZE AND LOCATION OF FEEDER DUCTS AND RETURN AIR DUCTS. ALL PLANS SHALL BE DRAWN TO SCALE.

ESTIMATED COST OF COMPLETED PROJECT: \$ 1100.00

DATE 10/31/77 APPLICANT'S SIGNATURE Elden Von Deylen
OWNER-CONTRACTOR-AGENT

